

LOBO POST PULLER OWNERS MANUAL

MODEL NO. _____

SERIAL NO. _____

IF YOU HAVE ANY QUESTIONS PLEASE CONTACT US AT

BY MAIL: **AMMBUSHER INC.**
 PO Box 456
 Dillsboro, IN 47018

SHIPPING
ADDRESS: **10470 Industrial Circle**
 Dillsboro, IN 47018

BY PHONE: **1-800-432-5955**
 812-432-3484 FAX

BY E-MAIL: **jawad@ammbusher.com**

LOBO POST PULLER

TABLE OF CONTENTS

DESCRIPTION	PAGE
WARRANTY	
Exclusion of Warranties	1
INTRODUCTION	
General Description	2
Features and Advantages	2
SAFETY	
Hydraulic Safety	3
Operating Safety	4
Safety Decal Location	5
OPERATION	
Pulling Operation	6
Changing Clamps	7-8
SERVICE AND MAINTENANCE	
Parts List	9
Model Parts Breakdown	10-11
Hydraulic Parts List	12

LOBO WARRANTY

AMMBUSHER, Inc. warrants each new product to be free from defects in material and workmanship.

For 90 days from the date of purchase, when the attachment has been maintained and lubricated in accordance with the operating and maintenance instructions in the Owners Manual, AMMBUSHER will replace free of charge, any defect in material or workmanship in this product.

This warranty does not cover:

This warranty excludes cam clamps and replaceable jaws on the V-brace, which are expendable and become worn during normal use.

Repairs on the LOBO POST PULLER because of alteration, an accident, or operator abuse or negligence, including the failure to maintain and operate the equipment according to instructions contained in the Owners Manual, or if repairs have been made with parts other than those obtainable through AMMBUSHER, Inc.

Our obligation under this warranty shall be limited to repairing and replacing, free of charge to the original purchaser, any part that in our judgement shows evidence of a defect, provided the part is routed through the dealer and distributor from whom the purchase was made, transportation charges prepaid.

This warranty shall not be interpreted to render us liable for injury or damages of any kind. This warranty does not extend to any expense or loss incurred for labor, supplies, substitute machinery rental, or any other reason.

This warranty is subject to any existing condition of supply which may directly affect our ability to obtain materials or manufacture replacement parts.

AMMBUSHER, Inc. reserves the right to make improvements in design or changes in specifications at any time, without incurring any obligations to owners of units previously sold.

No one is authorized to alter, modify, or enlarge this warranty nor the exclusions, limitations and reservations.

Every AMMBUSHER product is the highest quality. If you wish to contact us regarding this product, please call toll free between 8:00 a.m. and 4:30 p.m. EST, Monday through Friday. 1-800-432-5955.

INTRODUCTION

GENERAL DESCRIPTION

The LOBO post puller attachment will remove a fence post or guardrail from the ground in one step, making it a one person job. This machine will pull round fence posts and also many shapes and sizes including T-posts and I-Beam guardrails. Take time to review and familiarize yourself with this Owner's Manual paying special attention to the safety and the operation sections.

1. Post Clamp Jaws
 - a. Post clamp jaw assemblies are adjustable to pull post sizes 1" thru 8" in diameter.
 - b. Virtually any shape, round, square, T-posts, H post, can be clamped and pulled.
 - c. Able to grip and pull wood or steel posts.
 - d. Clamp jaws are made from hardened steel, and will pull many posts before requiring replacement parts.
 - e. Jaws are easily replaced. No tools required.
2. Post puller is quickly and easily connected to a skid steer, or other similar machinery. Mechanical and hydraulic hookup are quick and easy for any skid steer.
3. Post is loaded into the puller from the front, (as opposed to loading the machine over the top of the post). Posts can be removed and replaced while leaving an existing fence intact.
4. Post puller rests on the ground, requiring no lifting of post/concrete until post is completely broken free from the ground.
5. Machine is designed for minimum depth so it takes up less "Lane Space" when working on Highway jobs.
6. Post can be removed by one person.
7. Breakout pulling force of 17,000 lbs.

SAFETY

HYDRAULIC SAFETY

1. Always place hydraulic controls in neutral before dismounting your loader.
2. Make sure that all components in the hydraulic system are kept in good condition and are clean.
3. Replace any worn, cut, abraded, flattened, or crimped hoses and fittings.
4. Place hydraulic controls in neutral, and wait for all moving parts to stop before servicing, adjusting, repairing or unplugging. **Cycle machine completely to the unclamped/down position before attempting servicing.**
5. Do not attempt any makeshift repairs of the hydraulic lines, fittings or hoses by use of tape, clamps or cement. The hydraulic system operates under extreme high-pressure. Such repairs may fail suddenly and create a hazardous and unsafe condition.
6. Before applying pressure to the system, make sure all components are tight and that lines, hoses, and quick couplings are properly connected.
7. Wear proper hand and eye protection when searching for a hydraulic leak. Use a piece of wood or cardboard as a backstop instead of hands to find a leak. Hydraulic fluid escaping under pressure can have sufficient force to penetrate skin and cause serious injury, and if fluid is injected into the skin it must be surgically removed within a few hours by a doctor familiar with this form of injury or gangrene may result.

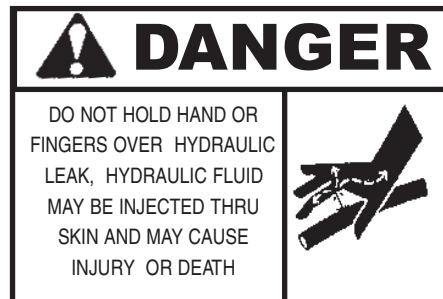

SAFETY

OPERATING SAFETY

1. Read and understand the Owner's Manual and all safety decals before connecting, disconnecting, or adjusting or operating this machine.
2. Do not allow riders on this attachment during operation or transport.
3. Keep hand, feet, hair, and clothing away from all moving and clamping parts.
4. Place hydraulic and skid steer controls in neutral, and wait for all moving parts to stop before servicing, adjusting, repairing or unplugging. **Cycle machine completely to the unclamped/down position before attempting servicing.**
5. Use caution when stepping over hydraulic hoses on entering and exiting machine.
6. When operating this machine, insure that you are at least 25 ft. from the nearest bystander, especially children.
7. When releasing a post from the gripping jaws, be careful. The post/concrete will fall to the ground which could result in injury to bystanders.
8. Stay away from overhead obstructions and power lines during setup and operation. Electrocutation can occur even without direct contact.
9. Insure that Post Push Bar is installed prior to pulling a post or any object that could fall into the cab. The post push bar also can be used as a handhold for safer entry and exit from the loader.
10. Review all safety instructions annually.
11. Do not attempt to remove any type of telephone/utility poles with this machine. Due to the height and weight of these type of poles, it may cause an unstable and unsafe conditions for the operators or bystanders.

 Remember, YOU are the key to safety. Good safety practices not only protect you but also the people around you from injury or death.

SAFETY DECALS AND DECAL LOCATION

The types of decals and locations on the equipment are shown in the illustration below. Good safety requires that you familiarize yourself with the various Safety Decals, the type of warning and the area, or particular function related to that area. If Safety Decals have been damaged, removed, become illegible or parts replaced without decals, new decals must be applied. New decals are available from your authorized dealer or from AMMBUSHER, INC.

1. Keep safety decals and signs clean and legible at all times.
2. Replace safety decals and signs that are missing or have become illegible.

DECALS INCLUDED IN 84769 DECAL KIT

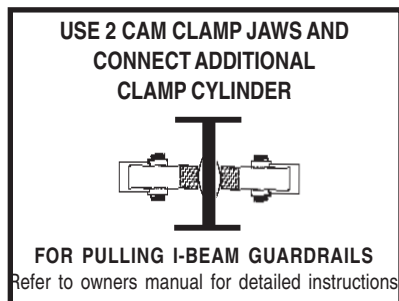

CAM CLAMP DECAL

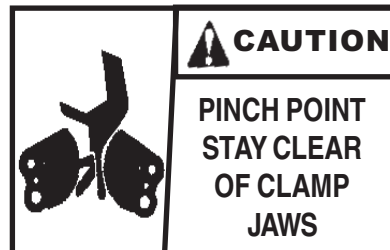

CAUTION PINCH POINT DECAL



DANGER HYDRAULIC LEAK DECAL

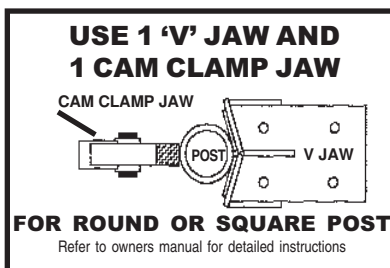

V-JAW CLAMP DECAL



MADE IN THE USA DECAL

NOTE: See parts breakdown on page 10 for proper decal placement.

OPERATION

The method of operation is as follows:

Hookup - Please read your skid steer owners manual. The hookup procedure is the same as other powered attachments for your skid steer loader.

1. Drive up to the post, aligning post gripping jaw and V-clamp with the post.



2. **IMPORTANT:** Use extreme caution not to set unit on bystanders foot. Set machine base flat on the ground by lowering the skid steer loader arms and using the “bucket roll” function of the loader. The machine base must set on the ground to develop the required breakout force.

3. Activate the hydraulic auxiliary circuit. The post will be clamped and pulled from the ground in one easy operation.
4. Once broken loose from the ground, the puller and the post can be raised out of the hole by lifting the loader arms and carried to a desired location.
5. Post may be carried to the “drop” location, and released by activating the hydraulics to cause reverse flow, thus unclamping the post.



IMPORTANT: Make sure the area is clear when unclamping the post. A falling post may cause injury or death to a bystander or may cause unnecessary damage to other equipment.

SERVICE AND MAINTENANCE



Place hydraulic controls in neutral, and wait for all moving parts to stop before servicing, adjusting, repairing or unplugging. **Cycle machine completely to the unclamped/down position before attempting servicing.** Hydraulic fluid escaping under pressure can have sufficient force to penetrate skin and cause serious injury, and if fluid is injected into the skin it must be surgically removed within a few hours by a doctor familiar with this form of injury or gangrene may result.

Metal burrs located on the cam clamps may inflict injury. Wear proper hand and eye protection when changing cam clamps or maintaining the unit.

LUBRICATION: Periodically remove pins and pivot bolts and apply a heavy grease such as Moly-Graph high pressure grease or equivalent to all points. This is especially important on the clamp jaws.

HYDRAULICS: Replace hoses that are showing wear. Replacement hydraulic hoses are available from Ammbusher, Inc. When changing hoses, make sure all components are tight and that lines, hoses, and quick couplings are properly connected before applying pressure to the system.

**Directions for changing cam clamps
to a V-jaw with SHORT THROW**

**FOR PULLING I-BEAM
GUARDRAILS**

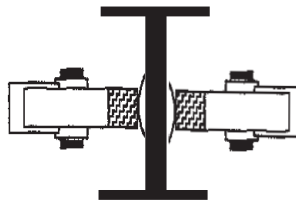

1. **IMPORTANT:** Follow all hydraulic and machine safety procedures listed above in the Operating and Safety section of your LOBO owners manual.
2. Remove Cylinder Plate from storage bracket located on the bottom of the unit.
3. Unscrew nuts and remove the Brace Weldment. Attach it to the storage bracket located on the bottom of the unit.
4. Align the Cylinder Plate and reattach nuts.
5. Attach the hydraulic hoses.
6. Unpin and remove the SHORT THROW cam clamp on the right hand cylinder plate and attach the LONG THROW cam clamp.

**Directions for changing cam
clamps to a V-Jaw with
SHORT THROW.**

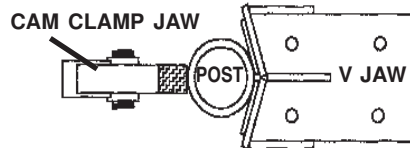

FOR USE WITH A ROUND OR SQUARE POST



1. **IMPORTANT:** Follow all hydraulic and machine safety procedures listed above in the Operating and Safety section of your LOBO owners manual.

2. Unhook hydraulic hoses attached to the left hand Cylinder. Place hydraulic hoses in the hose storage brackets.
3. Remove Brace Weldment from storage bracket located on the bottom of the unit.
4. Unscrew nuts on the left hand Cylinder Plate. Remove the Cylinder Plate and attach it to the storage bracket located on the bottom of the unit.
4. Align the Brace Weldment and reattach nuts.
5. Unpin and remove the LONG THROW cam clamp on the right hand cylinder plate and attach the SHORT THROW cam clamp.

PARTS LIST

F/N	P/N	QUANTITY		DESCRIPTION
		P1100	P1200	
1	84754	1	1	Cylinder Plate Weldment (RH)
2	84665	0	1	Cylinder Plate Weldment (LH)
3	84751	0	2	Clamp Jaw Long Throw
4	84699	1	1	Clamp Jaw Short Throw
5	84780	1	3	Shear Pin 1/2" D.x2" Long
6	84666	1	1	Brace Weldment
7	84768	2	2	Replaceable Jaw
8	84802	1	1	Link Arm Weldment (Lower Assy. Not Shown)
9	84803	2	2	Link Arm Stabilizer (Upper Assembly)
10	84642	2	2	Link Arm (Upper Assembly)
11	84772	2	2	Socket HD Cap Screw 1/4"-20 x 3/4 long
12	84332	8	8	1/2" - Lock Nut
13	84333	8	8	1/2" - Lock Washer
14	84674	2	2	Lift Cylinder
15	84758	2	2	1" dia. 3-1/2" Long Clevis Pin
16	84755	1	2	1" dia. x 2-3/4" Long Clevis Pin
17	84759	3	4	1" Flat Washer
18	84837	3	4	1" Rue Ring Cotter Pin
19	84757	1	2	3/4" dia. x 2-3/4" Long Clevis Pin
20	84756	1	2	3/4" dia. x 2" Long Clevis Pin
21	84671	2	4	3/4" Flat Washer
22	84836	2	4	3/4" rue Ring Cotter Pin
23	84670	8	8	5/8" dia. x 1-3/4" Long Clevis Pin
24	84838	4	4	5/8" dia. x 2-1/4" Long Clevis Pin
25	84839	12	12	5/8" dia. 18ga. Flat Washer
26	84840	12	12	5/8" Rue Ring Cotter Pin
27	84761	2	2	1" - 14 UNF x 4" Long Hex HD Bolt
28	84762	2	2	1" - 14 UNF Nut
29	84763	2	2	1" dia. Lock Washer
30	84675	1	2	Clamp Cylinder
31	84773	1A	1B	Hydraulic Hose Assy.(See p.11 for breakdown)
32	84774	1	1	Flow Divider/ Return Manifold
33	84781	2	2	5/16" Locknut
34	84752	2	2	5/16" Washer
35	84417	1	1	Q.D. Coupler
36	84418	1	1	Q.D. Coupler
37	84753	1	1	Safety Bar
38	84778	2	2	Snap Pin
39	84769	1	1	Decal Kit
40	84769-1	1	1	Caution Label Decal (Decal Kit)
41	84769-2	1	1	Hydraulic Hose Set (Decal Kit)
42	84769-3	1	1	V-Jaw Decal (Decal Kit)
43	84769-4	1	1	Cam Clamp Decal (Decal Kit)
44	84769-5	1	1	Made in USA Decal (Decal Kit)
44	84548	1	1	ID Tag
45	84783	1	1	Lobo Decal
46	84771	1	1	Non-Skid Tape Kit

P1100

Note: Post Push Bar not completely shown for clarity

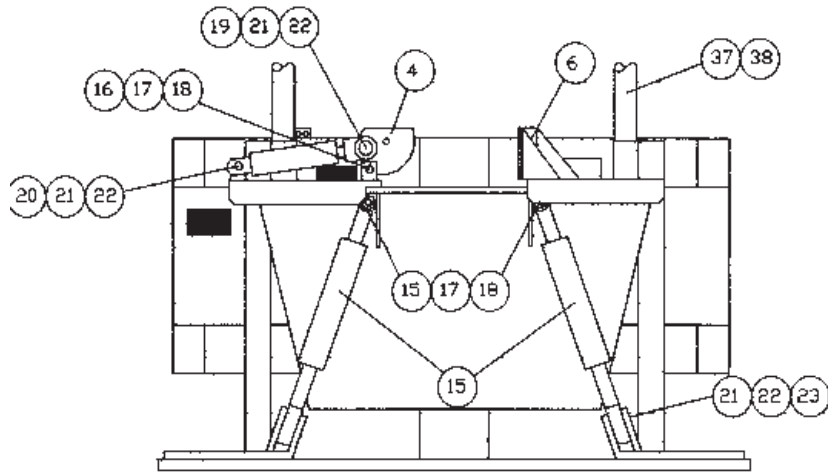
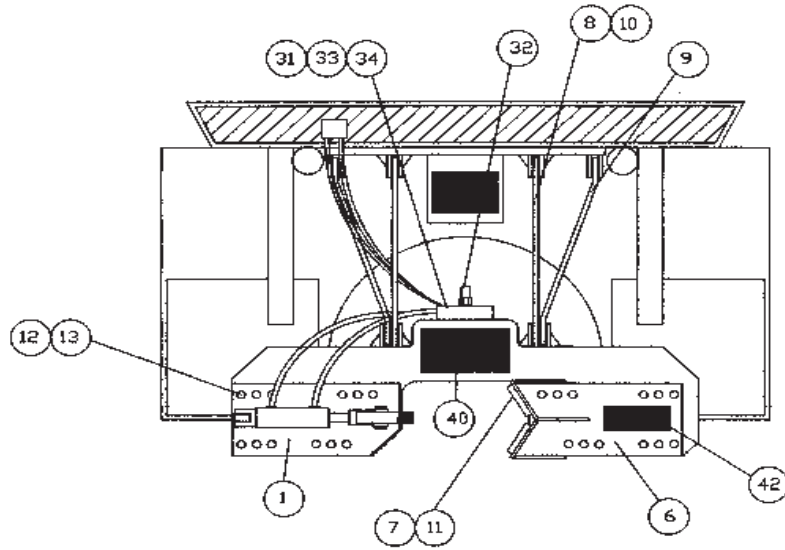

P1200

Note: Post Push Bar not completely shown for clarity

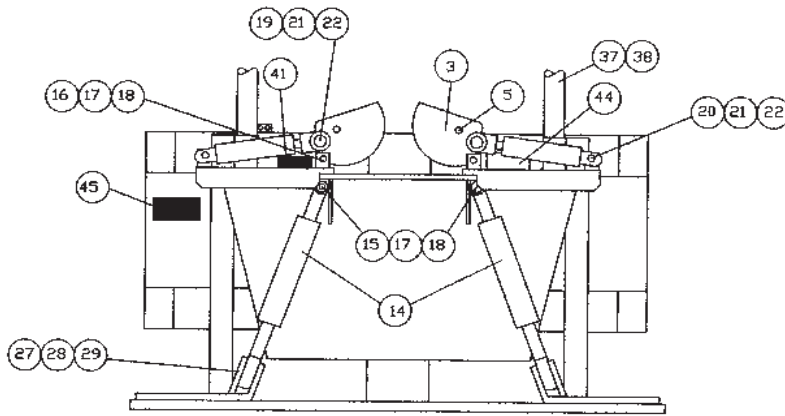
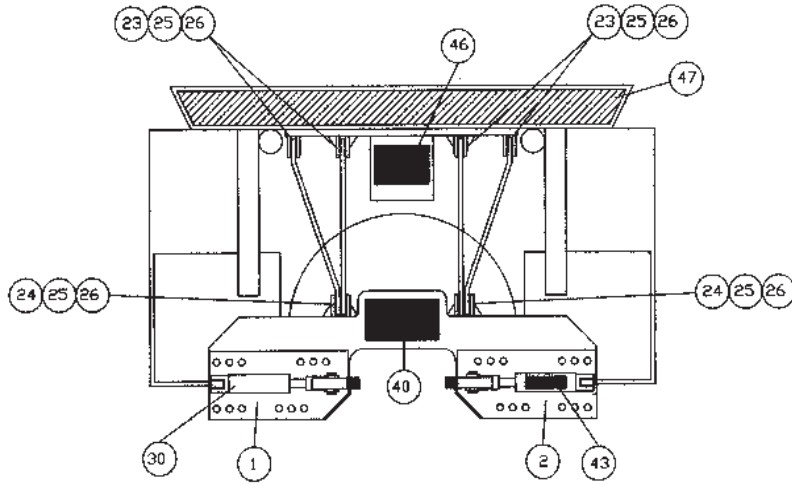

HYDRAULIC SCHEMATIC

Model P 1100/1200

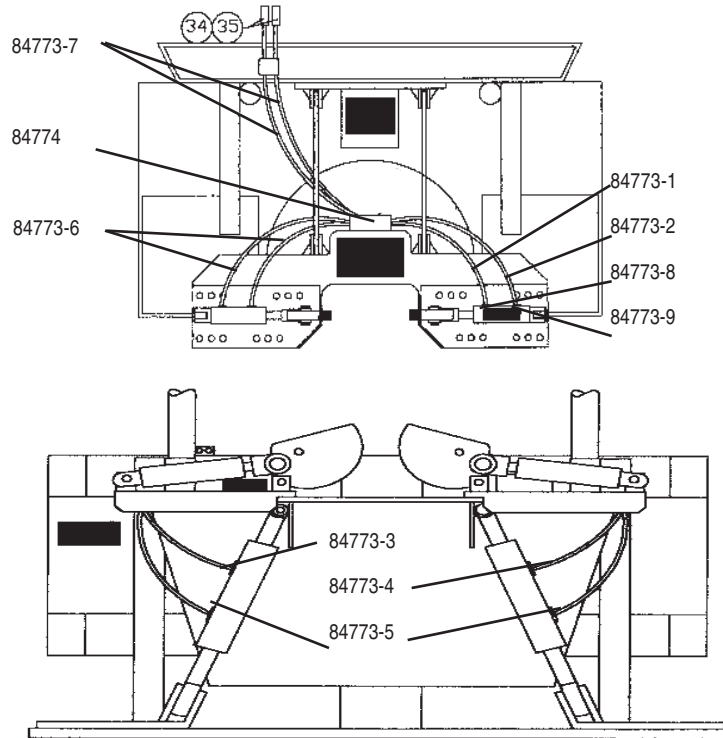

F/N 29 Hydraulic Assembly Kit:			
PART NO.	QTY.	PART	DESCRIPTION
84773-1	1	Hose Assy	Left Side Clamp Cyl. Retract (Female QD included on hose)
84773-2	1	Hose Assy	Left Side Clamp Cyl. Extend (Male QD included on hose)
84773-3	1	Hose Assy	Right Side Pull Cyl. Extend
84773-4	1	Hose Assy	Left Side Pull Cyl. Extend
84773-5	2	Hose Assy	Left and Right Side Clamp Cyl. Retract
84773-6	2	Hose Assy	Left and Right Side Pull Cyl.
84773-7	2	Hose Assy	Loader Connection (QD not included)
84773-8	1	QD	Male Quick Disconnect attached to Aux. Cyl.
84773-9	1	QD	Female Quick Dissconnect attached to Aux. Cyl.

F/N 34 & 35 Hydraulic Quick Disconnect not included in Assembly kit.			
PART NO.	QTY.	PART	DESCRIPTION
84417	1	QD	Quick Disconnect - female end
84418	1	QD	Quick Disconnect - male end

F/N 30 Manifold			
PART NO.	QTY.	PART	DESCRIPTION
84774	1	Manifold	Manifold Block